

---

**KIT PART NUMBER 1677138**  
**INSTRUCTIONS FOR INSTALLING FRONT AND SIDE PANELS ON A**  
**280 ZOOM**

**CHECK THE PARTS RECEIVED IN THE KIT WITH THE PARTS LIST IN THESE INSTRUCTIONS. IF ANY PARTS ARE MISSING, CONTACT THE NATIONAL VENDORS PARTS DEPARTMENT IMMEDIATELY.**

**Read these instructions carefully before installing the kit.**

**Keep these instructions for part numbers and for future reference.**

**This kit contains the following :**

<b>PART NUMBER</b>	<b>DESCRIPTION</b>	<b>QUANTITY</b>
1677140	SIDE PANEL ASSEMBLY - RIGHT - GLACIER SILVER	1
1677139	SIDE PANEL ASSEMBLY - LEFT - GLACIER SILVER	1
1677141	BASE PLATE & ACCESSORY - GLACIER SILV. (CONTAINS THE FOLLOWING ITEMS)	1
1470062	PAD - PACKAGING - BASE PLATE	2
1677137	BASE PLATE ASSEMBLY - HINGED - GLACIER SILVER	1
1411194	SLIDE - BASE PLATE - R.H.	1
1411195	SLIDE - BASE PLATE - L.H.	1
6231087	BRACKET - BASE PLATE	2
9900098	COTTER PIN 3/32 X 3/4 IN	2

**WARNING**

***DO NOT MOVE THE CABINET WHILE FASTENERS ARE LOOSENED. THE CABINET WOULD BECOME UNSTABLE AND LIKELY TO TIP AND CAUSE INJURY.***

1. Remove the floor liner and filler plate (if present) from the inside of the merchandiser to gain access to the holes as shown.
2. On each of the two left legs, loosen the outer hex nut as shown in the figure. ***Only loosen one nut per leg.***
3. Attach the left side panel assembly by fitting the smaller slots on the side panel over the leg mounting bolts.
4. Tighten the bolts.
5. Repeat step 2 through step 4 to attach the right side panel.
6. Loosen the two inner bolts on the left front leg.
7. Secure one of the base plate brackets to the left front leg assembly using the two bolts. Tighten the bolts and nuts on the left side.
8. Repeat steps step 6 and step 7 for the right hand side.

**Copyright 5/5/00**

9. Insert the short arms of the slides into the hinged tabs of the base plate. Position the slide so the notch near the short arm is on the bottom side.
10. Insert the long arms of the slides into the base plate brackets.
11. Insert and secure a cotter pin through the hole in the back of each of the slides.
12. Push the base plate toward the merchandiser cabinet. The front tabs of the base plate brackets should seat in the notches in the long arms of the slides.
13. Replace the parts you removed in step 1.

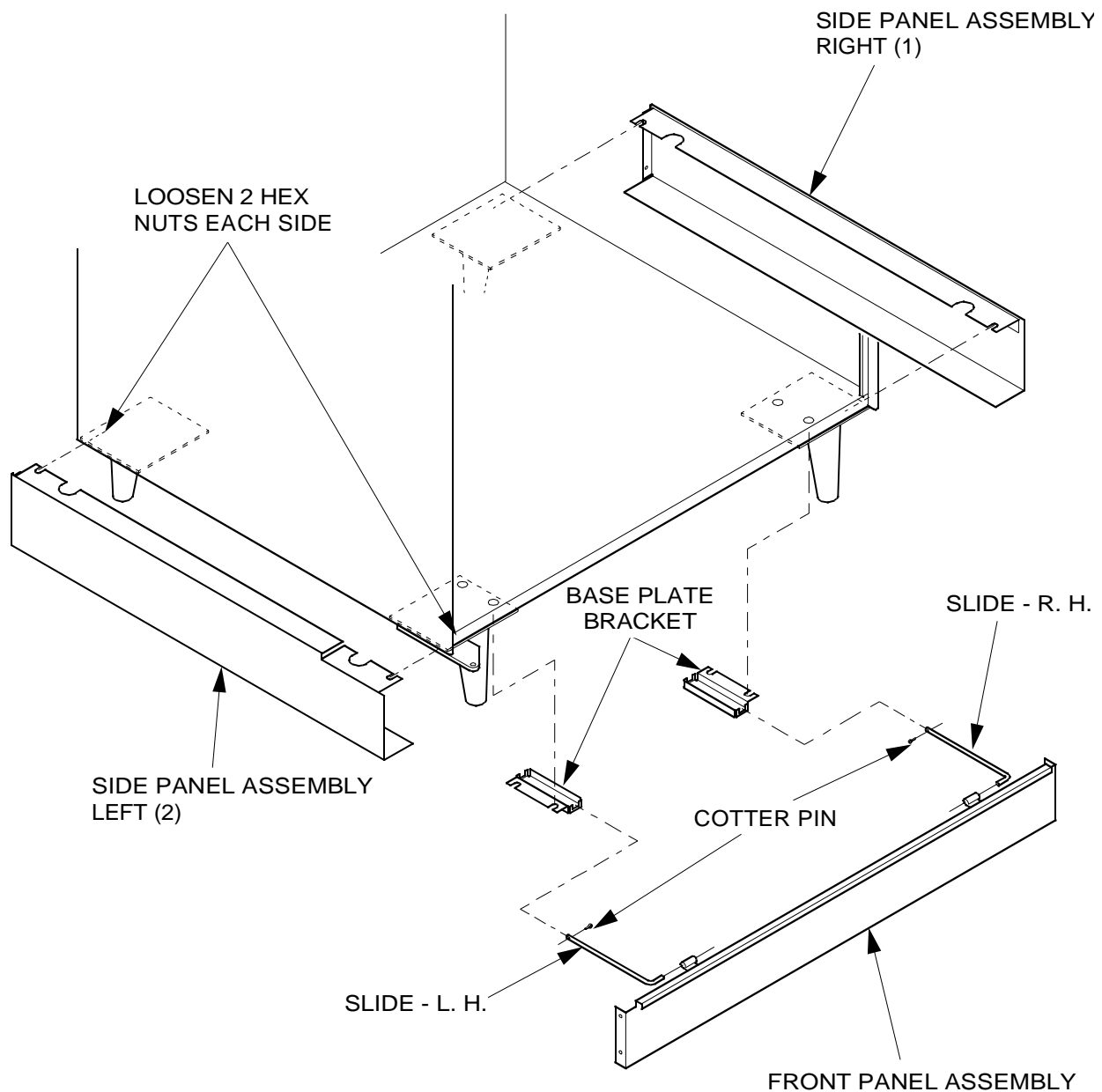

168p0003